

INFRARED SENSOR INSTRUCTION

GLD-808TR-220

PLEASE READ AND SAVE THIS MANUAL

GENERAL:

New generation infrared sensor by our long-term market forecast and investigation. It has strong stability. It incorporates automatic, convenient, energy-saving, safe and practical. It works by human motion infrared rays. It can start the controlled load at once when body enters detection field. It can identify day and night automatically. Its installation is very convenient and using range is wide. It is suitable for automatic control for home, hotel and enterprise.

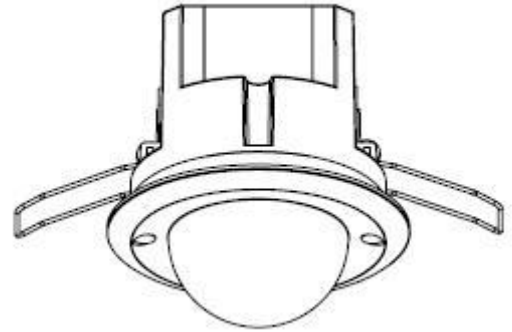

SPECIFICATIONS:

- Power source: 90V/AC~240V/AC Power frequency: 50~60 Hz
- Detection distance: 8m max (<22°C)
- Detection range: 120°(side view) 360°(top view)
- Light-control: 3LUX~1000lux (adjustable)
- Time-delay: 10±5sec~15±2min (adjustable)
- Rated load: Maximum 2000W incandescent lamp (resistive load/220V/AC)
Maximum 500W fluorescent lamp (inductive load/220V/AC)
- Installation height: 2m~4m
- Power consumption: 0.5W (static 0.1W)
- Detection motion speed: 0.6~1.5m/s
- Working humidity: <93%RH
- Working temperature: -20~40°C

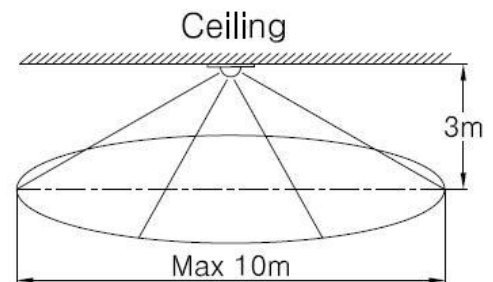

FUNCTION:

- Practicality: It can work in various ambient-light day and night, Time-delay can be adjusted by yourselves in stipulated range; infrared detection can be controlled by yourselves.

- Good appearance: The surface design is facility, comely but not losing generosity, the style is elegance, it will not have accident feeling after installed.
- Wide working voltage: 90V/AC~240V/AC 50~60Hz. You will not be worried all over the world if you carry VST-PD311TL.
- Convenient installation: It can be installed in circular or quadrate junction box; you could fix the sensor with two springs on the junction box.
- Adjusting the Lux control: The Lux control has a built-in photosensitive component that detects daylight and darkness. Turning the control towards the [sun] symbol will result in the unit switching in all light levels. Turning the control towards the [moon] symbol will result in the unit switching only in reduced light. Set the unit to switch at the desired light level using this control.
- Adjusting the duration time: The duration time is the length of time for which the load remains energized after the sensor has been triggered. This time can be adjusted from 10±5sec~15±2min. Turning the control from the [+] symbol to the [-] symbol will reduce the duration time.

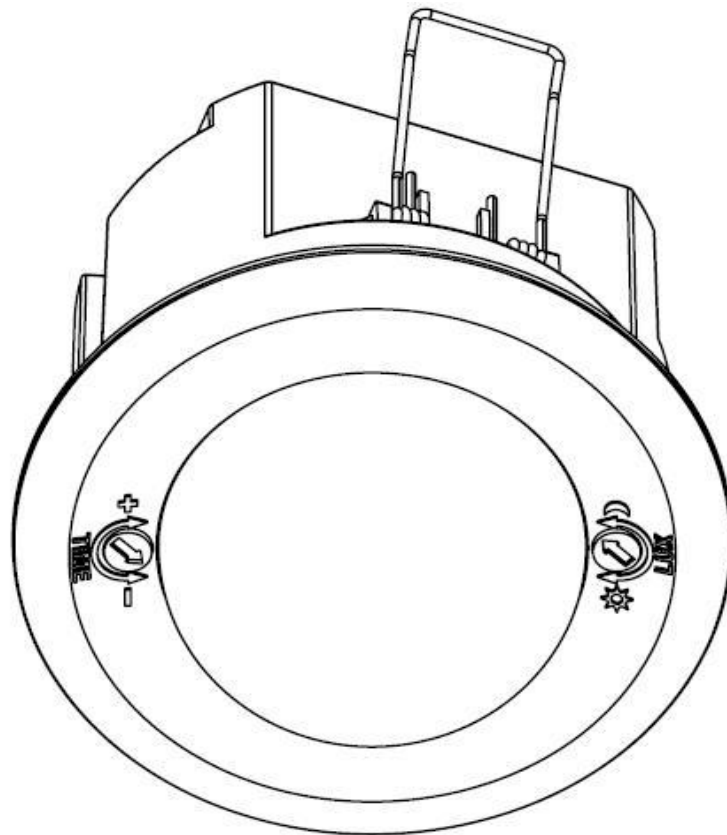

INSTALLATION:

- Shut off the power.
- Choose the location for your new PIR switch according to the conditions listed above.
- Cut a round hole 2.5 inch (65mm) in diameter in your mounting surface.
- Using a small flat-bladed screwdriver, remove the transparent cover from the mains terminals.
- Remove the top of the cord grip from the top of the PIR unit.
- Put the Live (IN) wire into connection hole L↑, and put the Neutral (IN) wire into connection hole N ,and put the



Bend the springs upwards and
Insert the PIR into the hole.

Live (OUT) wire into connection hole L↓, and put the Neutral(OUT) wire into connection hole N, and tighten the screws.

- Fit the cables under the cable grip and tighten securely.
- Press the cover back into position, and fit the screw.
- Set the Lux control to the day position (sun symbol) and the time control to minimum.
- Press the side springs upwards against the side of the unit and offer up into the hole allowing the strength of the springs to hold it in position.

CONNECTION-WIRE DIAGRAM (see the following figure)

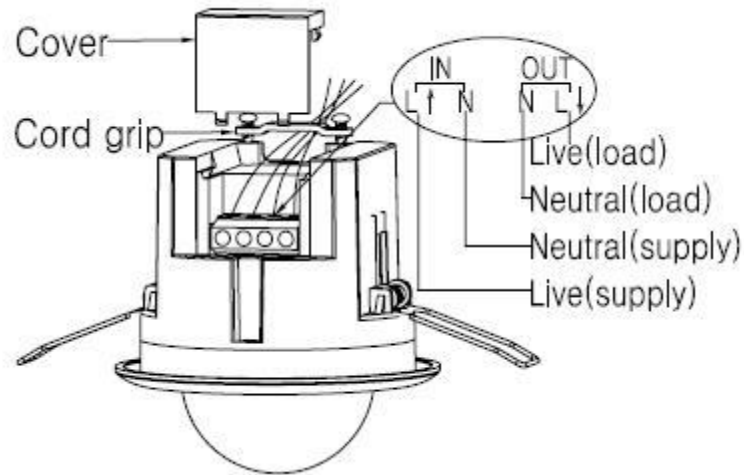

TEST:

- Turn the time control towards the [-] symbol, and turn the Lux control to the [sun] symbol.
- After switch on the power, the controlled load shouldn't work,, the load should work after 15-20sec. Under the no inductor signals condition, the load should stop working within 20~30sec.
- After 5~10sec to sense, the load should work. The load should stop working within 5~15sec.
- Turn the time control, and you can set time delay freely between 10±5sec and 15±2min.
- Turn the Lux control to the [moon] symbol. The inductor load shouldn't work in the more than 3LUX ambient-light. If you cover the detection window with the opaque objects (towel etc), the load should work. Under the no inductor signals condition, the load should stop working with in stipulated time.

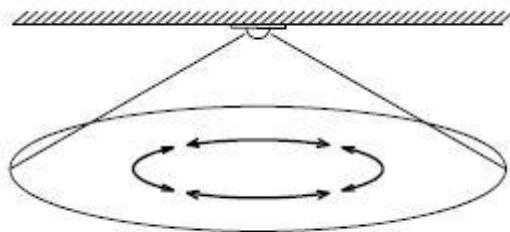

Movement direction with greatest
sensor sensitivity

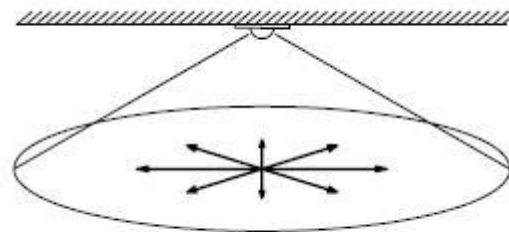

Movement direction with least
sensor sensitivity

NOTE:

- Electrician or experienced human can install it.
- The unrest objects can not be regarded the installation basis-face.
- There is not hinder or unrest objects effecting detection in front of the detection window.
- Avoid installing it near temperature alteration zones, for example, air condition, central heating etc.
- Do not open the case for your safety if you find the hitch after installation.
- If there is any difference between instruction and products, please give priority to product, sorry not to inform you again.

SOME PROBLEM AND SOLVED WAY

- The load does not work:
 - a. Check the power and the load.
 - b. If the load is good.
 - c. Please check if the working light corresponds to the ambient light.
- The sensitivity is poor:
 - a. Please check if the front of the detection window has the hinder that effect to receive the signals.
 - b. Please check the ambient temperature.
 - c. Please check if the signals source is in the detection fields.
 - d. Please check the installation height.
 - e. If the moving orientation is correct.
- The sensor can not shut automatically the load:
 - a. If it has the continual signals in the detection fields.
 - b. If the time delay is longest.
 - c. If the power correspond to the instruction.
 - d. If the air temperature changes near the sensor, for example air condition or central heating etc.

Globalchip S.L.

Cl. Marqueses de Barberà nº 98, Local - 08210 - Barbera del Valles
(BARCELONA) ESPAÑA

Tel: +34 902 875 228

E-mail: globalchip@globalchip.es Website: www.globalchip.es